

- Interface** Compatible with all OMNIBUS host products
Consumes one interrupt to host
- Power Requirements** 5 V @ 60mA; +15 V @ 80mA; -15 V @ 80mA
Forced air cooling required (30CFM)
- Physicals** OMNIBUS mezzanine card; 2.000 x 4.600 inches
- A/D Converters** 2 stereo Crystal Semiconductor CS5396 SD converters
- Resolution** 24-bit
- Sample Rate (Fs)** 2-96 kHz
- Over sampling** 256 X
- Analog Input Range** Professional audio, 13 V RMS, AC coupled
- S/N Ratio** 100 dB
- THD** -95 dB
- Dynamic Range** 100 dB
- DC Gain Error** 5%
- Input Type** Balanced or unbalanced (differential or single-ended)
- Input Impedance** 7 kOhm
- Digital Filter Characteristics** Passband= .4604 x sample rate Fs; Passband ripple=.005 dB
Stopband=.5442 x Fs min; 63.42 x Fs max
- Group Delay** 34/Fs seconds
- Conversion**
- Trigger Sources** 24-bit host DDS
- Interface to DSP** Memory-mapped interface
- D/A Converters** 2 stereo output AKM AK4324 SD converters
- Resolution** 24-bit
- Oversampling** 128 X or 256 X speed dependent
- Output Range** Line levels \pm 2 V unbalanced (single ended)
- Output Analog Filter** 2 pole, 50 kHz
- Update Rate** 30-96 kHz, programmable via host DDS
- Dynamic Range** 105 dB
- S/N Ratio** 100 dB
- THD + Noise** 92 dB
- Output Control** Digital de-emphasis and attenuation control
- Conversion**
- Trigger Sources** 24-bit host DDS
- Interface to DSP** Memory-mapped interface

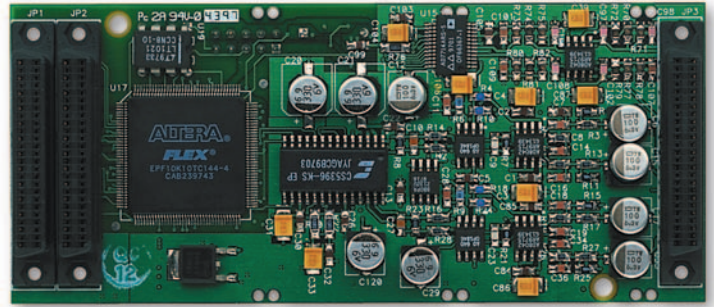

SD - Ultra-Performance Audio I/O Module

The SD module provides four channels of 24-bit, 96 kHz sigma-delta A/D and D/A conversion for state-of-the-art audio and SONAR applications. Each channel operates with extremely low noise, delivering better than 100 dB of S/N performance for ultra-clean signal acquisition and playback. The sigma-delta architecture provides highly effective digital anti-alias filtering removing all out-of-band signals.

The SD module has balanced (differential) input capability for maximum noise rejection at the front end. Careful attention was paid to op-amp selection to minimize noise and distortion, providing a clean front-end to the A/D converter.

The SD module control logic conveniently maps the A/D and D/A communication as a 24-bit memory-mapped parallel interface, seamlessly accessed by the host card.

Please note, the SD module requires forced air cooling. The board is designed for use in industrial computers providing air flow of around 30CFM and directed on both faces of the board. Insufficient cooling may cause erratic operation, data corruption or fatal hardware failure. Contact our sales office for assistance.

Software examples demonstrating module operation and communication are included in the Zuma/Armada Toolsets. A full calibration report ships with every module.

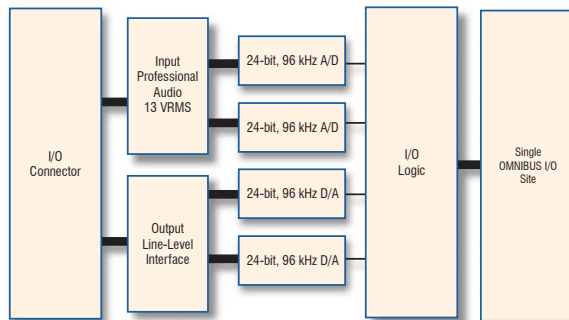

In System Performance

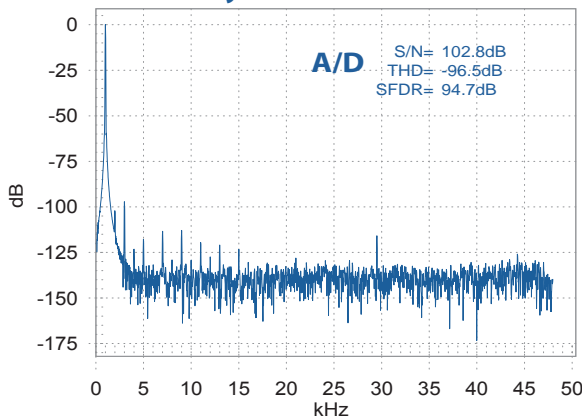

Ordering Information

SD

80020-7